

- Digital compression load cell, selfcentering column
- 4000 divisions OIML R60 class C
- Stainless Steel construction
- Hermetically welded, protection class IP 68 (EN 60529) and IP 69K (ISO 20653)
- Lightning protection
- Digital interface RS-485 fullduplex
- High speed of 200 readings/second
- Configuration and updatable software through serial interface
- Advantages in system setup, corner adjustment and individualized diagnosis
- Applications: High capacity weighing systems, truck scales

- Digitale Schwerlastwägezelle, selbstzentrierend
- 4000 Teile OIML R60 Klasse C
- Ausführung in Edelstahl
- Hermetisch dicht verschweißt Schutzart IP 68 (EN 60529) und IP 69K (ISO 20653)
- Blitzschutz
- Digitales Interface RS-485 Fullduplex
- Hohe Messrate von 200 Messungen/s
- Systemeinstellungen und SW-Update über serielle Schnittstelle
- Vorteile bei der Inbetriebnahme, beim Eckenabgleich und durch individuelle Diagnose
- Applikationen: Schwerlastwaagen, Strassenfahrzeugwaagen

Model Modell	Nominal capacity Nennlast Ln	Accuracy class Genauigkeitsklasse n. OIML	Minimum division Kleinster Teilungswert vmin	Safe load limit Grenzlast 150 % Ln	Breaking load Bruchlast
740D 15 t	15 t	4000	1.25 kg	22.5 t	> 52.5 t
740D 30 t	30 t	4000	2.5 kg	45 t	> 105 t
740D 40 t	40 t	4000	3.33 kg	60 t	> 140 t
740D 50 t	50 t	4000	4.17 kg	75 t	> 175 t
740D 60 t	60 t	4000	5 kg	90 t	> 210 t



**MODEL 740D + ACC. 74901 (15...50 t)**  
**ACC. 74905 (60 t)**

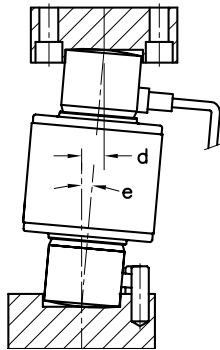
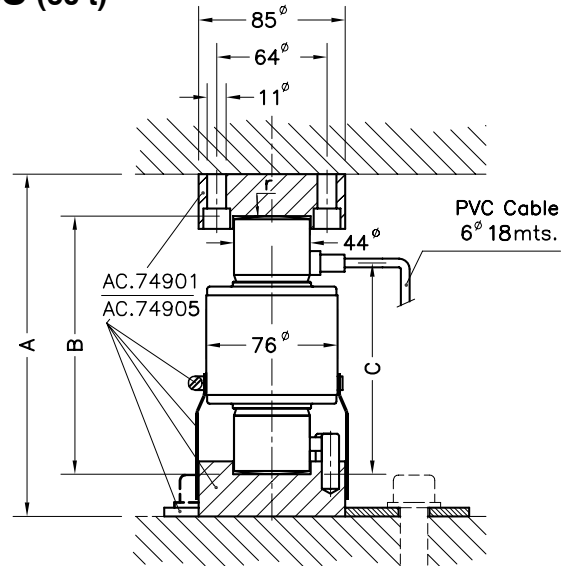
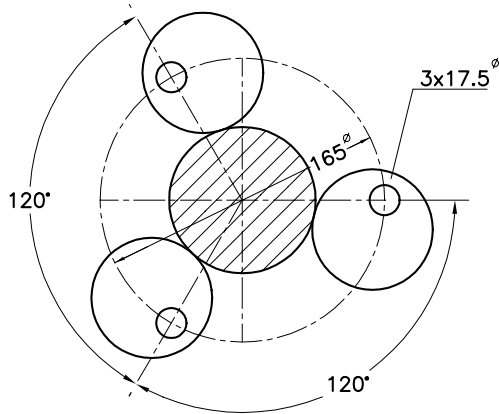

Load cells Wägezellen	A	B	C	d	e max. Max. Neigung	Radius Ball r	Transport Weight Transport- gewicht
740D 15 t	200	150	123	13	5°	130	2.5 kg
740D 30 t	200	150	123	13	5°	160	2.6 kg
740D 40 t	200	150	123	13	5°	180	2.8 kg
740D 50 t	200	150	123	13	5°	180	2.9 kg
740D 60 t	260	210	153	11	3°	220	3.8 kg
Acc.74901	-	-	-	-	-	-	3 kg
Acc.74905	-	-	-	-	-	-	3 kg

Dimensions in mm. Abmessungen in mm.

SPECIFICATIONS			TECHNISCHE DATEN
Nominal capacities (Ln)	15-30-40-50-60	t	Nennlasten (Ln)
Accuracy class	4000	n. OIML	Genauigkeitsklasse
Minimum dead load	0	%Ln	Minimale Vorlast
Service load	120	%Ln	Gebrauchslast
Safe load limit	150	%Ln	Grenzlast
Total error	< ±0.013	%Sn	Zusammengesetzter Fehler
Repeatability error	< ±0.01	%Sn	Wiederholgenauigkeit
Temperature effect: on zero	< ±0.01	%Sn/5 °C	Temperaturfehler: Nullpunkt
on sensitivity	< ±0.006	%Sn/5 °C	Kennwert
Creep error (30 minutes)	< ±0.012	%Sn	Kriechfehler (30 min)
Temperature compensation	-10...+40	°C	Nenntemperaturbereich
Temperature limits	-30...+70	°C	Arbeitstemperaturbereich
Nominal sensitivity (Sn)	200000±0.05%	counts (1)	Nennkennwert (Cn)
No load output	±0.1	%Sn	Nullsignaltoleranz
Power supply	8...18	V DC	Stromversorgung
Supply current	60	mA (max.)	Stromaufnahme
Conversion speed	200	Hz	Messrate
RS-485 Serial interface	Fullduplex	Baud	RS-485 Serial interface
Max. transmission cable length	4800...115200	m	Max. Kabellänge
Maximum deflection (at Ln)	1200	mm	
	0.6-1	mm	Nennmessweg (bei Ln)

ELECTRICAL CONNECTION  
ELEKTRISCHER ANSCHLUSS:

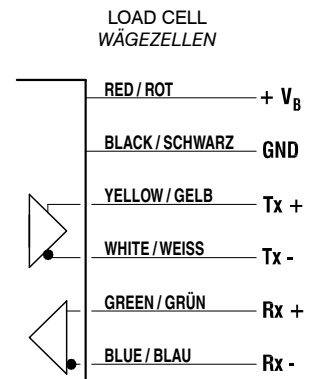

(1) User programmable / Benutzerprogrammierbar

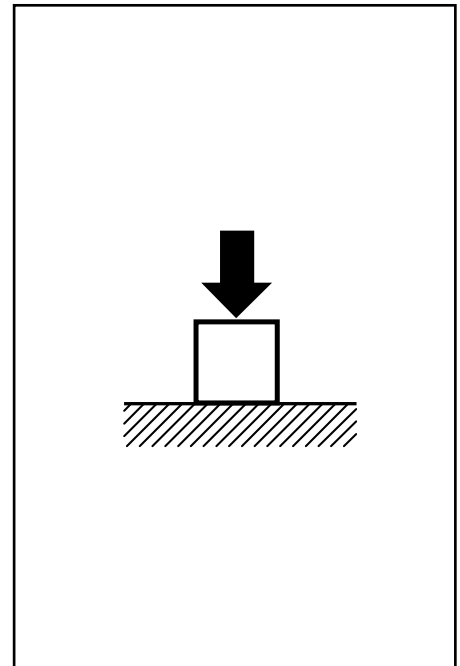
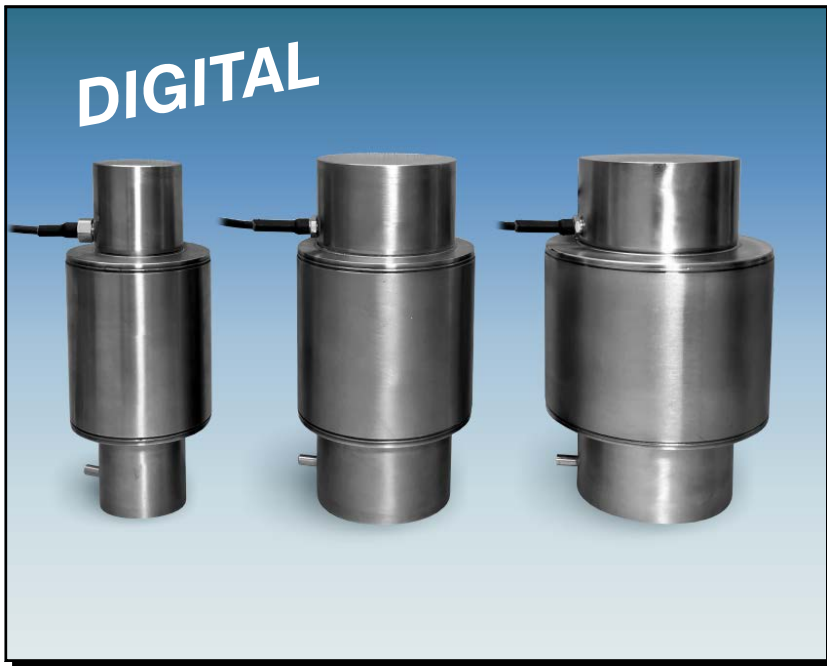

- Digital compression load cell, selfcentering column
- 1000 divisions OIML R60 class C
- Stainless Steel construction
- Hermetically welded, protection class IP 68 (EN 60529) and IP 69K (ISO 20653)
- Lightning protection
- Digital interface RS485 full duplex
- High speed of 200 readings/second
- Configuration and updatable software through serial interface
- Advantages in system setup, corner adjustment and individualized diagnosis
- Applications: High capacity weighing systems

- Digitale Schwerlastwägezelle, selbstzentrierend
- 1000 Teile OIML R60 Klasse C
- Ausführung in Edelstahl
- Hermetisch dicht verschweißt Schutzart IP 68 (EN 60529) und IP 69K (ISO 20653)
- Blitzschutz
- Digitales Interface RS-485 Fullduplex
- Hohe Messrate von 200 Messungen/s
- Systemeinstellungen und SW-Update über serielle Schnittstelle
- Vorteile bei der Inbetriebnahme, beim Eckenabgleich und durch individuelle Diagnose
- Applikationen: Schwerlastwaagen, Strassenfahrzeugwaagen

Model Modell	Nominal capacity Nennlast Ln	Accuracy class Genauigkeitsklasse n. OIML	Minimum division Kleinster Teilungswert vmin	Safe load limit Grenzlast 150 % Ln	Breaking load Bruchlast
740D 100 t	100 t	1000	15 kg	150 t	350 t
740D 200 t	200 t	1000	30 kg	300 t	450 t
740D 400 t	400 t	1000	60 kg	600 t	1200 t
740D 600 t	600 t	1000	90 kg	900 t	1800 t



# MODEL 740D +

ACC. 74904 (100...200 t)

ACC. 74911 (400 t)

ACC. 74912 (600 t)

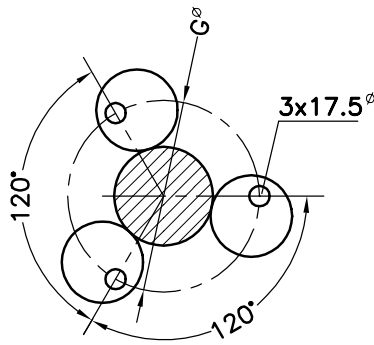
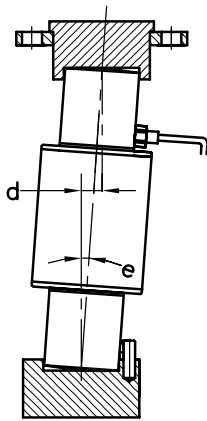

BOTTOM VIEW  
UNTERSICHT

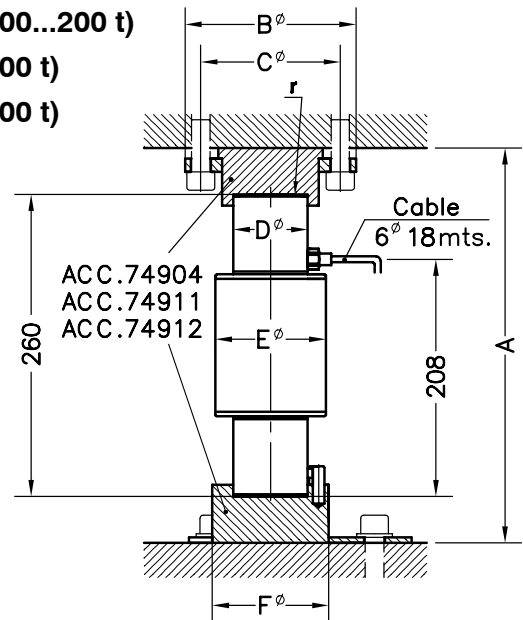

TOP VIEW  
DRAUFSICHT

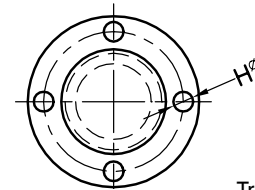

Load cells Wägezellen	A	B	C	D	E	F	G	H	d max.	e max. Max. Neigung	Radius Ball r	Transport Weight gewicht
740D 100 t	340	147	120	64	104	100	165	17	18	4°	290	11 kg
740D 200 t	340	147	120	64	104	100	165	17	9	2°	400	11 kg
740D 400 t	400	220	190	109	140	160	200	21	8	1.4°	700	23 kg
740D 600 t	400	220	190	118	169	160	200	21	8	1.4°	800	27 kg
Acc. 74904	---	---	---	---	---	---	---	---	---	---	---	7 kg
Acc. 74911	---	---	---	---	---	---	---	---	---	---	---	27 kg
Acc. 74912	---	---	---	---	---	---	---	---	---	---	---	36 kg

Dimensions in mm.  
Abmessungen in mm.

Transport Weight  
gewicht

SPECIFICATIONS			TECHNISCHE DATEN
Nominal capacities (Ln)	100-200- 400-600	t	Nennlasten (Ln)
Accuracy class	1000	n. OIML	Genauigkeitsklasse
Minimum dead load	0	%Ln	Minimale Vorlast
Service load	120	%Ln	Gebrauchslast
Safe load limit	150	%Ln	Grenzlast
Total error	< ±0.05	%Sn	Zusammengesetzter Fehler
Repeatability error	< ±0.01	%Sn	Wiederholgenauigkeit
Temperature effect: on zero	< ±0.01	%Sn/5 °C	Temperaturfehler: Nullpunkt
on sensitivity	< ±0.018	%Sn/5 °C	Kennwert
Creep error (30 minutes)	< ±0.048	%Sn	Kriechfehler (30 min)
Temperature compensation	-10...+40	°C	Nenntemperaturbereich
Temperature limits	-30...+70	°C	Arbeitstemperaturbereich
Nominal sensitivity (Sn)	200000±0.05%	counts (1)	Nennkennwert (Cn)
No load output	±0.1	%Sn	Nullsignaltoleranz
Power supply	8...18	V DC	Stromversorgung
Supply current	60	mA (max.)	Stromaufnahme
Conversion speed	200	Hz	Messrate
RS-485 Serial interface	Fullduplex 4800...115200	Baud	RS-485 Serial interface
Max. transmission cable length	1200	m	Max. Kabellänge
Maximum deflection (at Ln)	1.2-2.6	mm	Nennmessweg (bei Ln)

ELECTRICAL CONNECTION  
ELEKTRISCHER ANSCHLUSS:

LOAD CELL  
WÄGEZELLEN

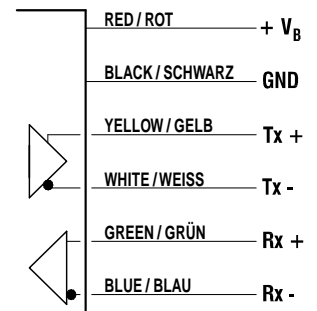

(1) User programmable / Benutzerprogrammierbar

## ACCESSORIES AND SCHEMATIC CONNECTION DIGITAL LOADCELL ZUBEHÖR UND SCHEMATISCHE VERBINDUNG DIGITALE WÄGEZELLE

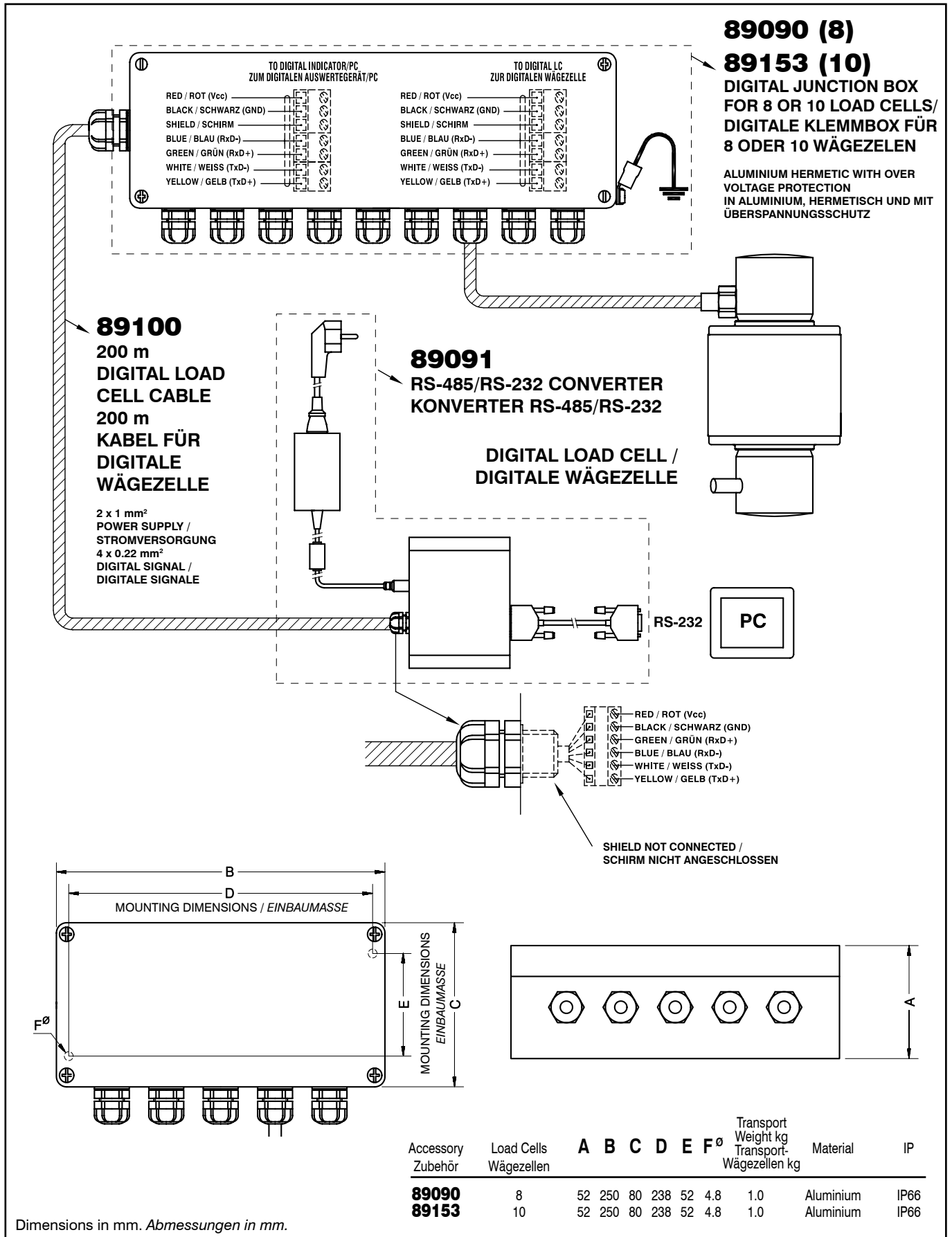

Dimensions in mm. Abmessungen in mm.

ACCESSORIES FOR MODEL 740 (15...60t)  
ZUBEHÖR FÜR MODELL 740 (15...60t)

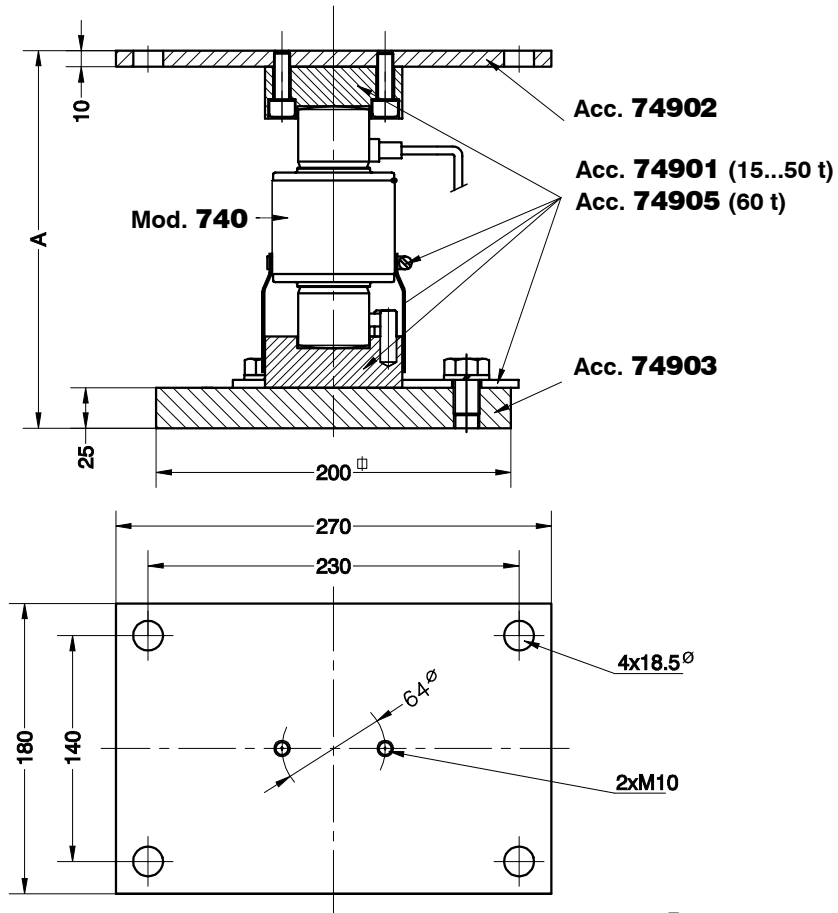

Accessory Zubehör	Model Modell	A	Accessory Zubehör	Transport Weight Transport- gewicht
<b>74901 + 74902 + 74903</b>	740 (15-20-25-30-40-50 t)	235	<b>74901</b>	3 kg
<b>74905 + 74902 + 74903</b>	740 (60 t)	295	<b>74902</b>	3.9 kg
			<b>74903</b>	9.7 kg
			<b>74905</b>	3 kg

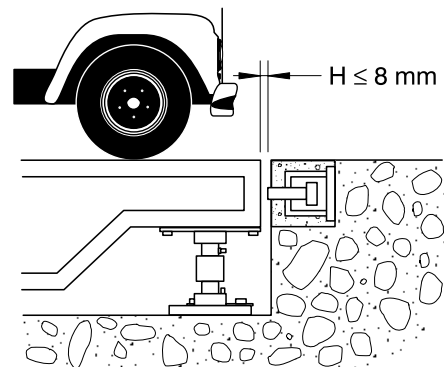
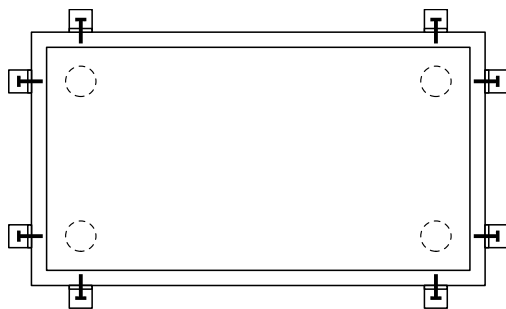

Dimensions in mm. Abmessungen in mm.

# MOUNTING KIT LIFT-OFF PREVENTION FOR SILO FOR M.740 (15...50t)

## LASTECKE MIT ABHEBESICHERUNG FÜR M.740 (15...50t)

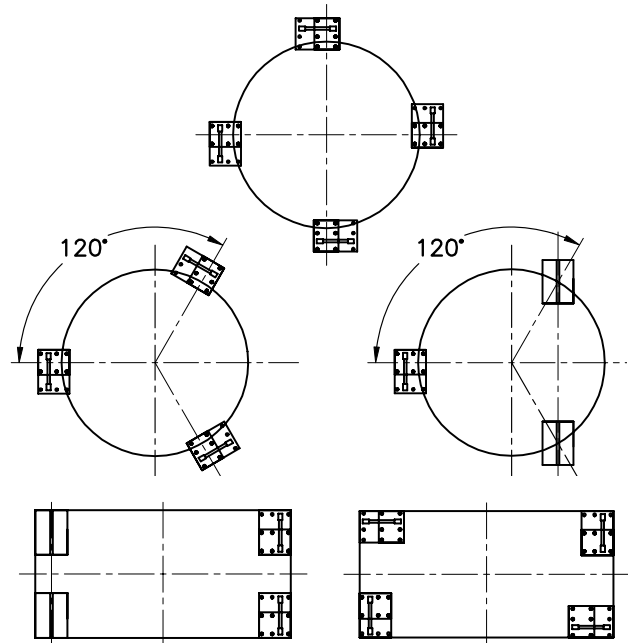
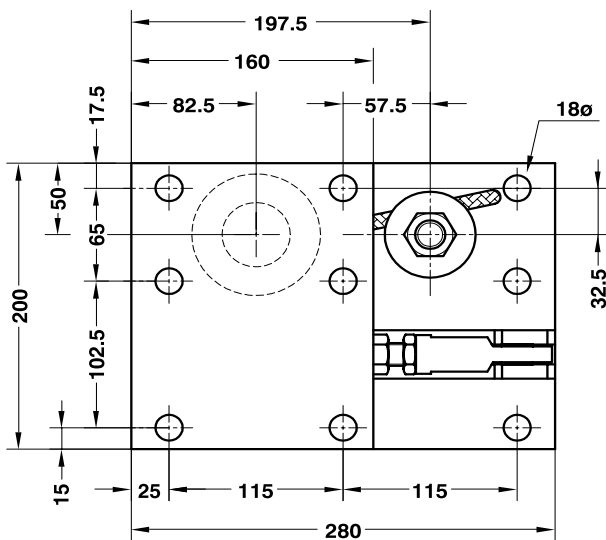
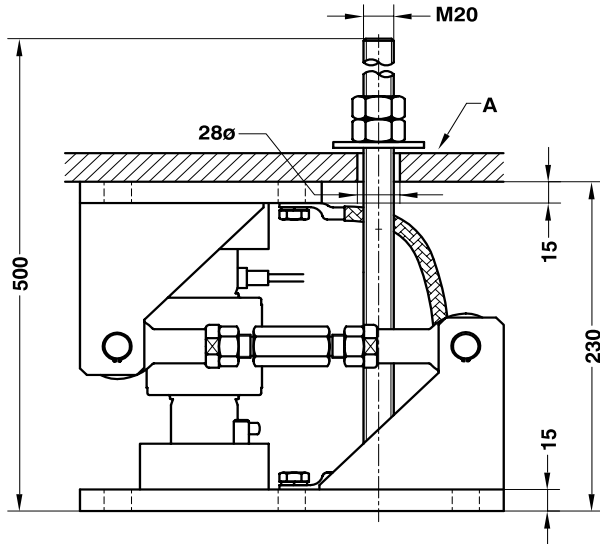

Nominal load	15...50 t	Nennlast
Max. permissible side offset transverse to retention arm	±4 mm	Max. zulässige Seitenverschiebung zur Lenkerrichtung
Permissible horitz. force in direction of the retention arm	47 kN	Max. zulässige Horizontalkraft zur Lenkerrichtung
Maximum permissible lifting force	76 kN	Max. zulässige Zugkraft vertikal
Max. permissible lifting movement, must be adjusted (A)	3 mm	Max. zulässiger Nennweg vertikal, muss eingestellt werden (A)
Material: Alloy Steel zinc-plated		Material: Verzinkter Stahl

Dimensions in mm. Abmessungen in mm.

Transport weight - Transportgewicht: 19 kg

# MOUNTING KIT LIFT-OFF PREVENTION FOR SILO FOR M.740 (60t) LASTECKE MIT ABHEBESICHERUNG FÜR M.740 (60t)

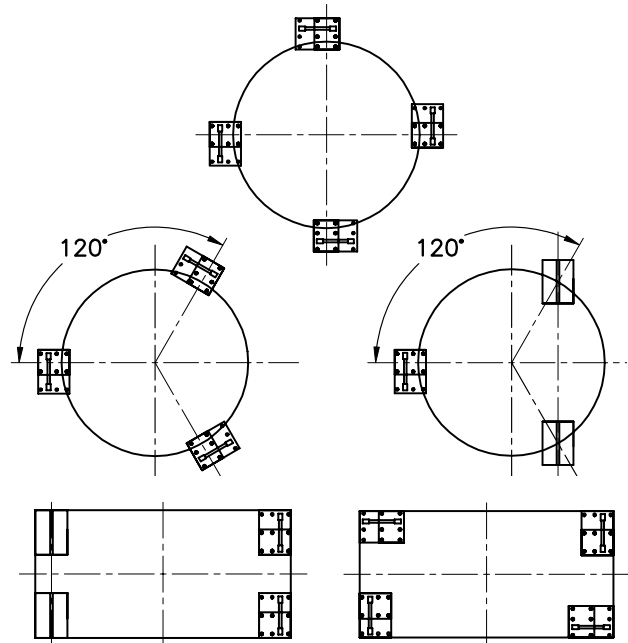
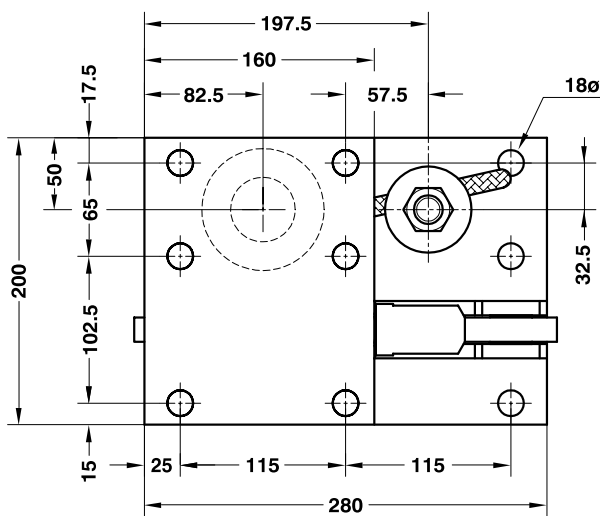
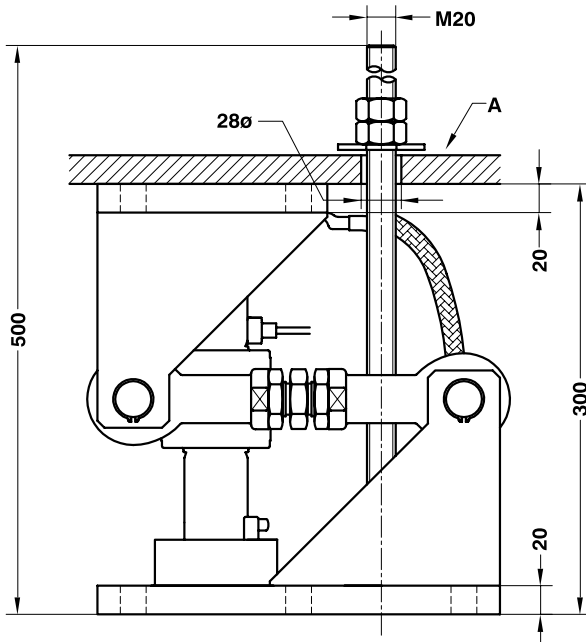

Nominal load	60 t	Nennlast
Max. permissible side offset transverse to retention arm	± 4 mm	Max. zulässige Seitenverschiebung zur Lenkerrichtung
Permissible horitz. force in direction of the retention arm	95 kN	Max. zulässige Horizontalkraft zur Lenkerrichtung
Maximum permissible lifting force	114 kN	Max. zulässige Zugkraft vertikal
Max. permissible lifting movement, must be adjusted (A)	3 mm	Max. zulässiger Nennweg vertikal, muss eingestellt werden (A)
Material: Alloy Steel zinc-plated		Material: Verzinkter Stahl

Dimensions in mm. Abmessungen in mm.

Transport weight - Transportgewicht: 27 kg



**MOUNTING KIT LIFT-OFF PREVENTION FOR SILO FOR M.740 (100...200t)**  
**LASTECKE MIT ABHEBESICHERUNG FÜR M.740 (100...200t)**

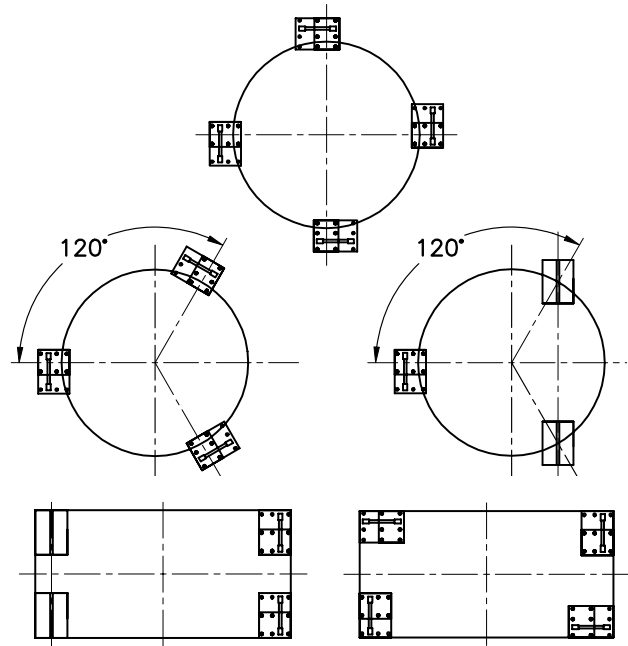
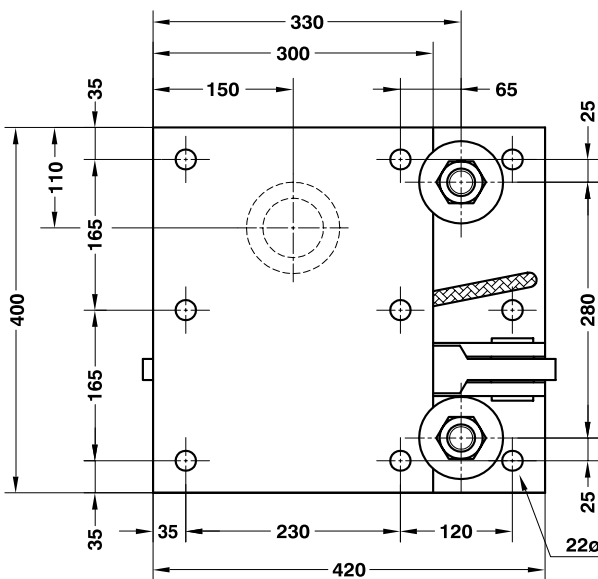
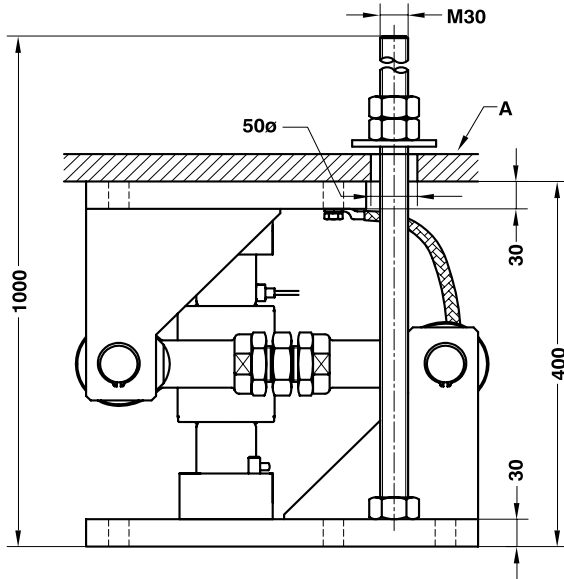

Nominal load	100...200 t	<i>Nennlast</i>
Max. permissible side offset transverse to retention arm	±5 mm	<i>Max. zulässige Seitenverschiebung zur Lenkerrichtung</i>
Permissible horitz. force in direction of the retention arm	180 kN	<i>Max. zulässige Horizontalkraft zur Lenkerrichtung</i>
Maximum permissible lifting force	228 kN	<i>Max. zulässige Zugkraft vertikal</i>
Max. permissible lifting movement, must be adjusted (A)	3 mm	<i>Max. zulässiger Nennweg vertikal, muss eingestellt werden (A)</i>
Material: Alloy Steel zinc-plated		<i>Material: Verzinkter Stahl</i>

Dimensions in mm. *Abmessungen in mm.*

Transport weight - *Transportgewicht:* 98 kg

# MOUNTING KIT LIFT-OFF PREVENTION FOR SILO FOR M.740 (400t) LASTECKE MIT ABHEBESICHERUNG FÜR M.740 (400t)

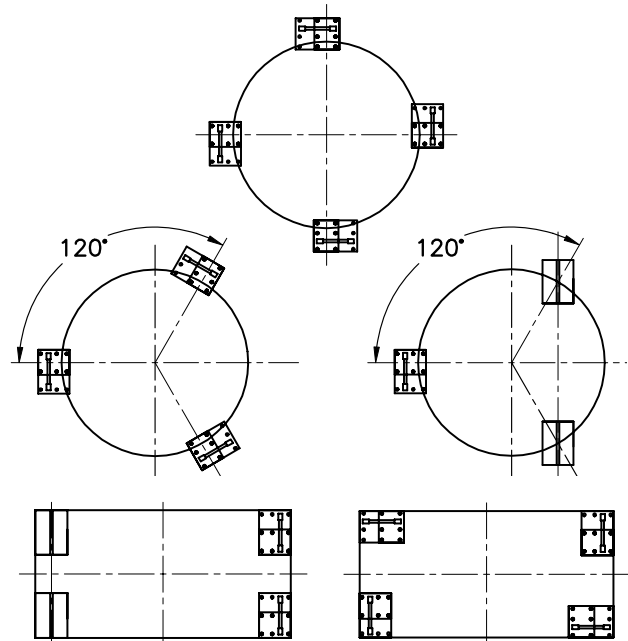
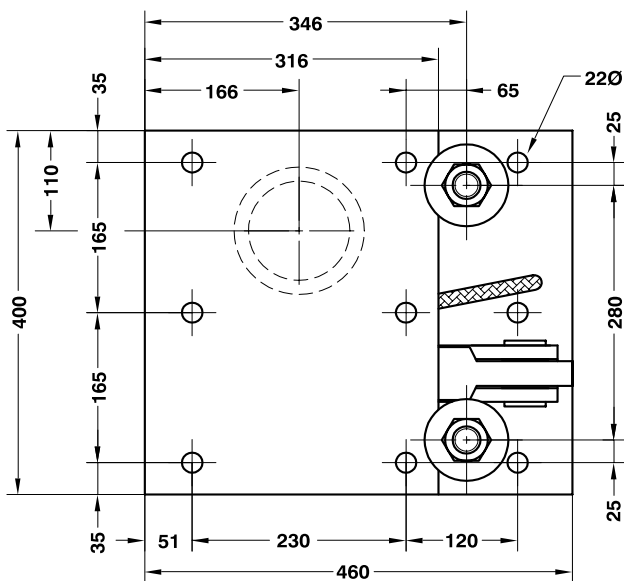
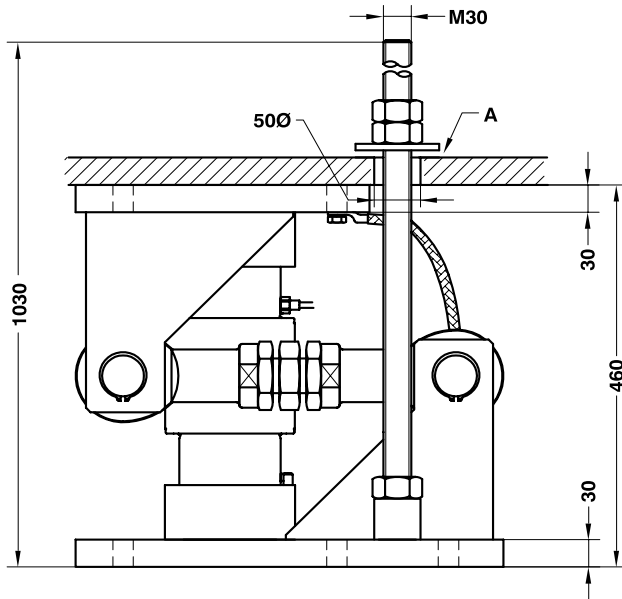

Nominal load	400 t	Nennlast
Max. permissible side offset transverse to retention arm	±5 mm	Max. zulässige Seitenverschiebung zur Lenkerrichtung
Permissible horitz. force in direction of the retention arm	240 kN	Max. zulässige Horizontalkraft zur Lenkerrichtung
Maximum permissible lifting force	330 kN	Max. zulässige Zugkraft vertikal
Max. permissible lifting movement, must be adjusted (A)	3 mm	Max. zulässiger Nennweg vertikal, muss eingestellt werden (A)
Material: Alloy Steel zinc-plated		Material: Verzinkter Stahl

Dimensions in mm. Abmessungen in mm.

Transport weight - Transportgewicht: 142 kg

# MOUNTING KIT LIFT-OFF PREVENTION FOR SILO FOR M.740 (600t)

## LASTECKE MIT ABHEBESICHERUNG FÜR M.740 (600t)

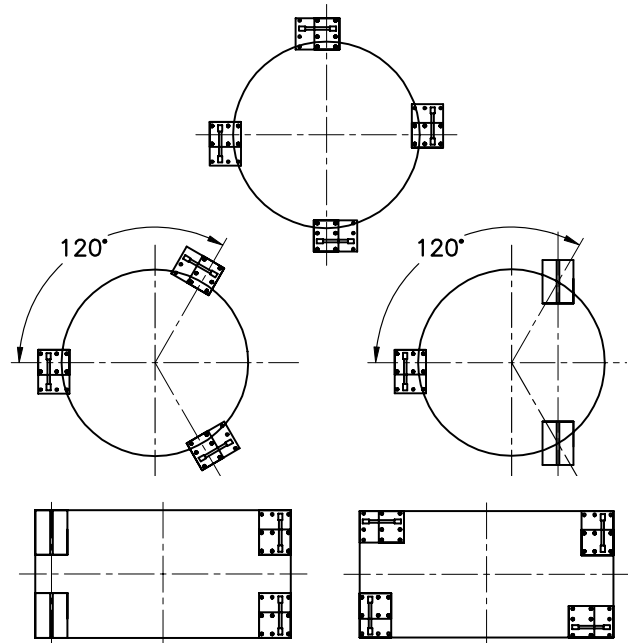
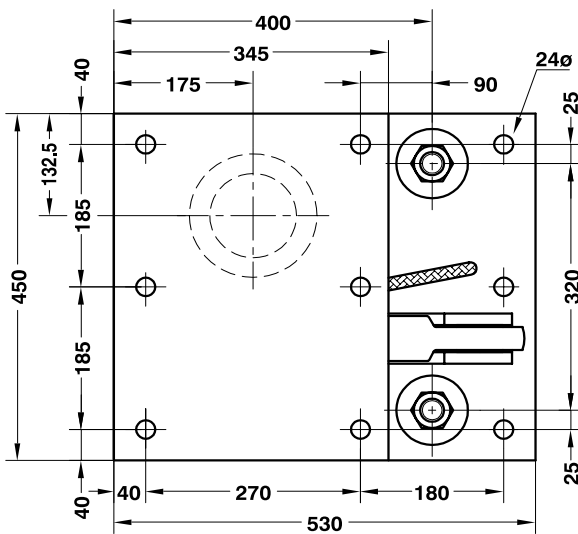
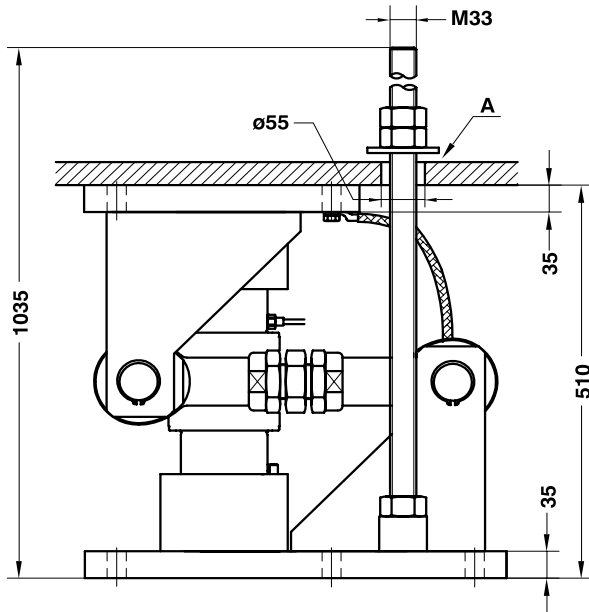

Nominal load	600 t	Nennlast
Max. permissible side offset transverse to retention arm	±5 mm	Max. zulässige Seitenverschiebung zur Lenkerrichtung
Permissible horitz. force in direction of the retention arm	290 kN	Max. zulässige Horizontalkraft zur Lenkerrichtung
Maximum permissible lifting force	395 kN	Max. zulässige Zugkraft vertikal
Max. permissible lifting movement, must be adjusted (A)	3 mm	Max. zulässiger Nennweg vertikal, muss eingestellt werden (A)
Material: Alloy Steel zinc-plated		Material: Verzinkter Stahl

Dimensions in mm. Abmessungen in mm.

Transport weight - Transportgewicht: 185 kg